

INTRODUCTION

Thank you for choosing an HK Instruments PS series differential pressure switch. The PS series is intended for use in commercial environments. It is designed with field selectable setpoint adjustment to meet your application requirements.

The PS series differential pressure switches is comprised of PS300 with range from 30...300 Pa, PS500 with range from 30...500 Pa, PS600 with range from 40...600 Pa, PS1500 with range from 100...1500 Pa and PS4500 with range from 500...4500 Pa.

APPLICATIONS

PS series devices are commonly used in HVAC/R systems for:

- fan, blower and filter monitoring
- pressure and flow monitoring
- valve and damper monitoring

SPECIFICATIONS

Performance

Accuracy (at applied pressure)

At low limit (Typical):

PS200: ± 5 Pa
PS300: ± 5 Pa
PS500: ± 5 Pa
PS600: ± 5 Pa
PS1500: ± 10 Pa
PS4500: ± 50 Pa

Switching differential:

PS200: 20 Pa
PS300: 20 Pa
PS500: 20 Pa
PS600: 30 Pa
PS1500: 80 Pa
PS4500: 250 Pa

Overpressure:

Proof pressure: 25 kPa
Burst pressure: 50 kPa

Technical Specifications

Media compatibility:

Dry air or non-aggressive gases

Measuring units:

Pa

Measurement range:

PS200: 20-200 Pa
PS300: 30-300 Pa
PS500: 30-500 Pa
PS600: 40-600 Pa
PS1500: 100-1500 Pa
PS4500: 500-4500 Pa

Environment:

Operating temperature: -20...60 °C
Storage temperature: -20...85 °C
Humidity: 0 to 95 % rH, non condensing

Physical

Dimensions:

Case: 105 x 73 x 63 mm

Weight:

150 g

Mounting:

2 each 4.3 mm screw holes, one slotted

Materials:

Case: ABS
Cover: PC
Membrane: Silicone
Duct connectors: ABS
Tubing: PVC

Protection standard:

IP54

Electrical connections:

3 screw terminals
Wire: 12-24 AWG (0.2-1.5 mm²)

Cable entry:

Strain relief: M16
Knockout: 16 mm

Pressure fittings:

Male \varnothing 5.0 mm

WARNING

- READ THESE INSTRUCTIONS CAREFULLY BEFORE ATTEMPTING TO INSTALL, OPERATE OR SERVICE THIS DEVICE.
- Failure to observe safety information and comply with instructions can result in PERSONAL INJURY, DEATH AND/OR PROPERTY DAMAGE.
- To avoid electrical shock or damage to equipment, disconnect power before installing or servicing and use only wiring with insulation rated for full device operating voltage.
- To avoid potential fire and/or explosion do not use in potentially flammable or explosive atmospheres.
- Retain these instructions for future reference.
- This product, when installed, will be part of an engineered system whose specifications and performance characteristics are not designed or controlled by HK Instruments. Review applications and national and local codes to assure that the installation will be functional and safe. Use only experienced and knowledgeable technicians to install this device.

Electrical

Input:

24-250 VAC

Output:

NO / NC circuit

Electrical rating, resistive load:

3 A / 250 VAC (PS200: 0.1 A / 250 VAC)

Electrical rating, inductive load:

2 A / 250 VAC (PS200: -)

Conformance

Meets requirements for CE marking:

RoHS Directive 2011/65/EU

LVD Directive 2014/35/EU

WEEE Directive 2012/19/EU

COMPANY WITH
MANAGEMENT SYSTEM
CERTIFIED BY DNV GL
= ISO 9001 = ISO 14001 =



SCHEMATICS

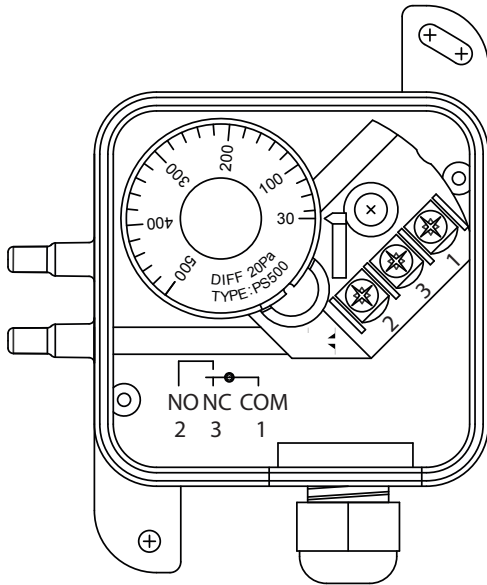

DIMENSIONAL DRAWINGS

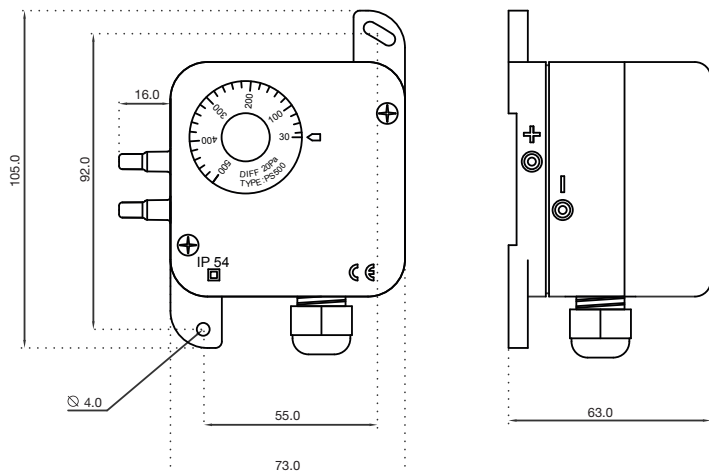

INSTALLATION

- 1) Mount the device in the desired location (see step 1).
- 2) Open the lid.
- 3) Select the desired switching point by turning the selection wheel.
- 4) Route the cables through the strain relief and connect the cables properly to the terminal block (see step 2).
- 5) Close the lid.

⚠ WARNING! Apply power only after the device is properly wired.

STEP 1: MOUNTING THE DEVICE

Mounting position:

To be installed in vertical position, either the pressure inlets or the electrical cable downwards. Select a location that provides as much protection from water sprays (e.g. rain) as possible.

Figure 1a - Surface mounting

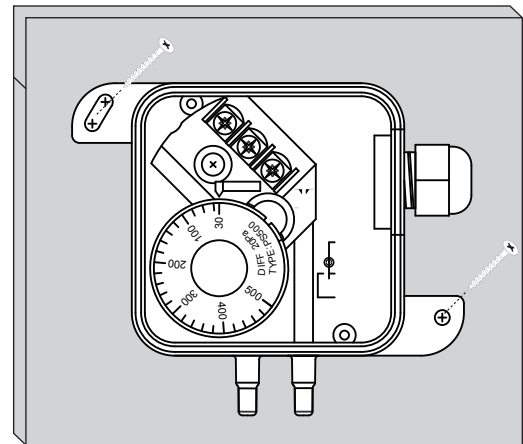
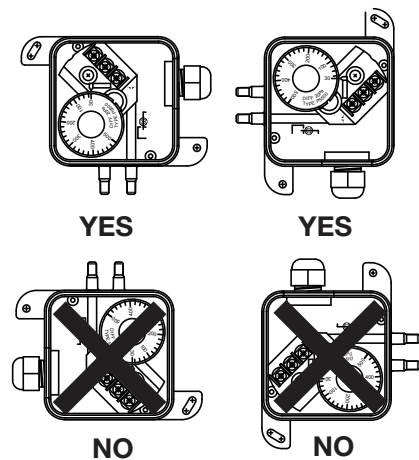

Figure 1b - Mounting orientation



STEP 2: WIRING DIAGRAMS

For CE compliance, a properly grounded shielding cable is required.

- 1) Unscrew the strain relief and route the cable.
- 2) Connect the wires as shown in Figure 2.
- 3) Tighten the strain relief.

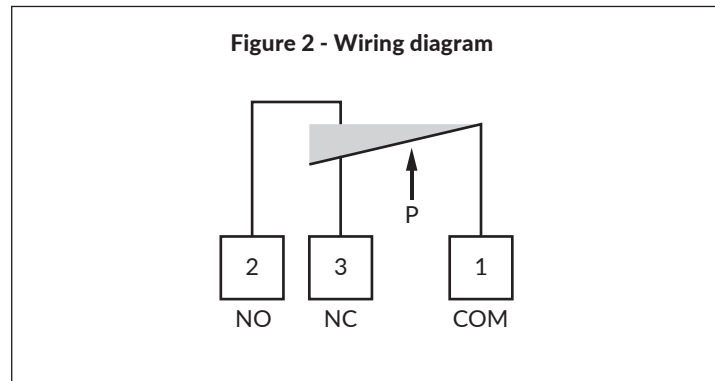

RECYCLING/DISPOSAL

The parts left over from installation should be recycled according to your local instructions. Decommissioned devices should be taken to a recycling site that specializes in electronic waste.



WARRANTY POLICY

The seller is obligated to provide a warranty of five years for the delivered goods regarding material and manufacturing. The warranty period is considered to start on the delivery date of the product. If a defect in raw materials or a production flaw is found, the seller is obligated, when the product is sent to the seller without delay or before expiration of the warranty, to amend the mistake at his/her discretion either by repairing the defective product or by delivering free of charge to the buyer a new flawless product and sending it to the buyer. Delivery costs for the repair under warranty will be paid by the buyer and the return costs by the seller. The warranty does not comprise damages caused by accident, lightning, flood or other natural phenomenon, normal wear and tear, improper or careless handling, abnormal use, overloading, improper storage, incorrect care or reconstruction, or changes and installation work not done by the seller or his/her authorized representative. The selection of materials for devices prone to corrosion is the buyer's responsibility, unless otherwise is legally agreed upon. Should the manufacturer alter the structure of the device, the seller is not obligated to make comparable changes to devices already purchased. Appealing for warranty requires that the buyer has correctly fulfilled his/her duties arisen from the delivery and stated in the contract. The seller will give a new warranty for goods that have been replaced or repaired within the warranty, however only to the expiration of the original product's warranty time. The warranty includes the repair of a defective part or device, or if needed, a new part or device, but not installation or exchange costs. Under no circumstance is the seller liable for damages compensation for indirect damage.